



# **Test Catalogue Driving Skill Tests**

**DTV  
German Traditional Drivers Association e.V.**

## Änderungshistorie

Date	Author	Description	Version Nr:
08.06.2017	L. Niemeyer	Created	1.0
22.10.2017	L. Niemeyer	Changes & Corrections	2.0
07.11.2017	L. Niemeyer	Corrections to Diagrams	3.0
12.02.2018	L. Niemeyer	Supplement 9. Correction to penalty points	4.0
22.03.2018	L. Niemeyer	Further correction penalty points, revision tasks	5.0
01.01.2023	M. Pfeifer	Further correction penalty points, revision tasks	6.0
12.03.2023	Mark Jurd	Translation	6.0

### Maintaining confidentiality:

This document is the property of the DTV German Traditional Drivers Association e.V. Its content is confidential and subject to copyright and may not be duplicated in whole or in part, passed on to third parties or published in any form without the express written permission of the DTV German Traditional Drivers Association e.V. This does not apply to copies intended for internal use.

## **Contents**

- 1. Stopping/ Halt at a Gate**
- 2. Stopping/ Halt between two line**
- 3. Stopping/ Halt on a hill / on a descent**
- 4. The Wooden Bridge**
- 5. Rein Back (level or slight uphill surface)**
- 6. Champagne Glass**
- 7. Passage / drive through**
- 8. With music**
- 9. With tractor**
- 10. With livestock**
- 11. With salute**
- 12. Driving between marked lines**
- 13. “ “ straight on**
- 14. “ “ with a left bend**
- 15. “ “ with a right bend**
- 16. “ “ by a livestock pen**
- 17. Driving Circles**
- 18. “ Circle left**
- 19. “ Circle right**
- 20. Half circle right through two pairs of cones**
- 21. Half circle left through two pairs of cones**
- 22. Use of the whip**
- 23. “ “ to knock balls off**
- 24. “ “ to ring a bell**
- 25. Folding a whip, only for Tandem, Teams and Coaches**
- 26. The Turnout in motion**
- 27. Stopping / coming to a halt**

# 1. Stopping

## 1.1 Stopping

Carriage Number ..... Whip's Name : .....

Gait: Walk Drive into the obstacle through gate A.

Stop the horses with their heads level with Line B / Gate B without using the brakes. Allow the team to stand still unassisted for 20 seconds. The clock starts when the turnout comes to a standstill.

The horses must stand still which is determined by the wheels being motionless

The brakes must not be used in any part of the obstacle. After 20 seconds, exit over / through line / gate B without knocking the balls off the cones.

Gate width: 2,50 m Single, Pair and Tandem  
2,80 m 3- horses, teams & Coaches

Distance between Gate A-B: 4,00 bis 6,00 m

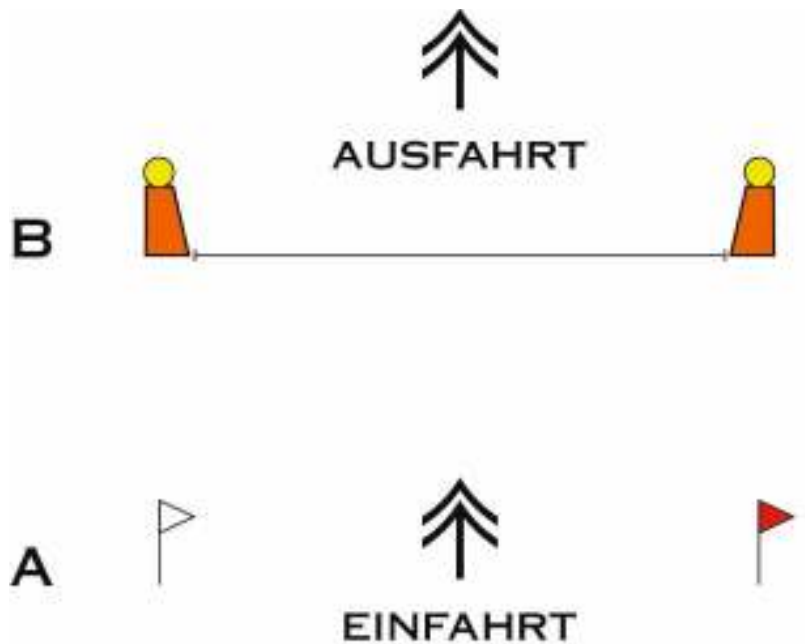

### Score

- Test completed without error
- Incorrect gait
- Ball knocked from cone
- The turnout failed to stop stop before Line B
- The turnout failed to stand still for 20 seconds
- Coachman used the brakes
- Whip not held in the hand
- Coachman received assistance
- Failure to complete the skill test or not entering the obstacle correctly Maximum penalty points

### Penalty Points

- 0
- 3
- 3
- 3
- 3
- 3
- 3
- 3
- 10

Obstacle Judge's name ..... Judge's signature: ..... Penalty Points: .....

## 2. Stopping in front of the Gate

Carriage Number .....

Coachman's Number .....

Gait: Walk

Bring the horses to a halt at stop line A without using the brakes

The turnout must remain standing without for a minimum of 20 seconds during which a passenger opens the gate. The clock starts as soon as the carriage is stationary.

The horses must stand still which is determined by the wheels being motionless

The brakes must not be used in any part of the obstacle.

The gate is traversed after the passenger is seated and the 20 seconds have elapsed

Gate width: 2,50 m Single, Pair and Tandem  
2,80 m 3- horses, teams & Coaches

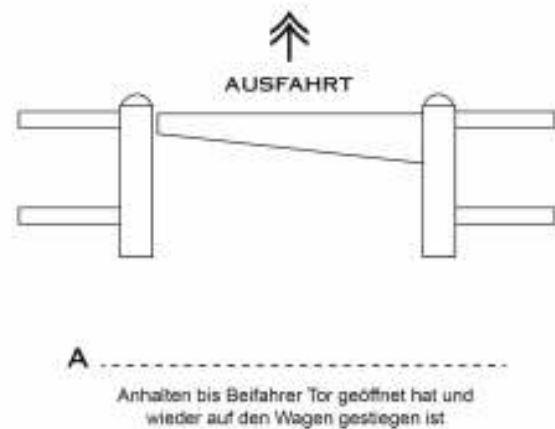

Remain stationary until the passenger has opened the gate and climbed back onto the carriage.

### Score

- Test completed without error
- Incorrect gait
- Ball knocked from cone
- The turnout failed to stop before Line A
- The turnout failed to stand still for 20 seconds
- Coachman used the brakes
- Whip not held in the hand
- Coachman received assistance
- Failure to complete the skill test or not entering the obstacle correctly Maximum penalty points

### Penalty Points

- 0
- 3
- 3
- 3
- 3
- 3
- 3
- 3
- 10

Obstacle Judge's name ..... Judge's signature: ..... Penalty Points: .....

### 2.3. Stopping between two lines

Carriage Number .....

Coachman's Name: .....

Gait: Walk

There are two clearly visible lines perpendicular to the direction of travel. The first line (A) has to be crossed. Then, without using the brake, you have to stop in such a way that the front wheels (both wheels on 1-axle vehicles) come to a standstill between lines A&B.

The horses must stand still which is determined by the wheels being motionless. The brakes must not be used in any part of the obstacle.

The clock starts as soon as the turnout is stationary.

Then exit over line B.

The distance between the lines is 1.5 meters

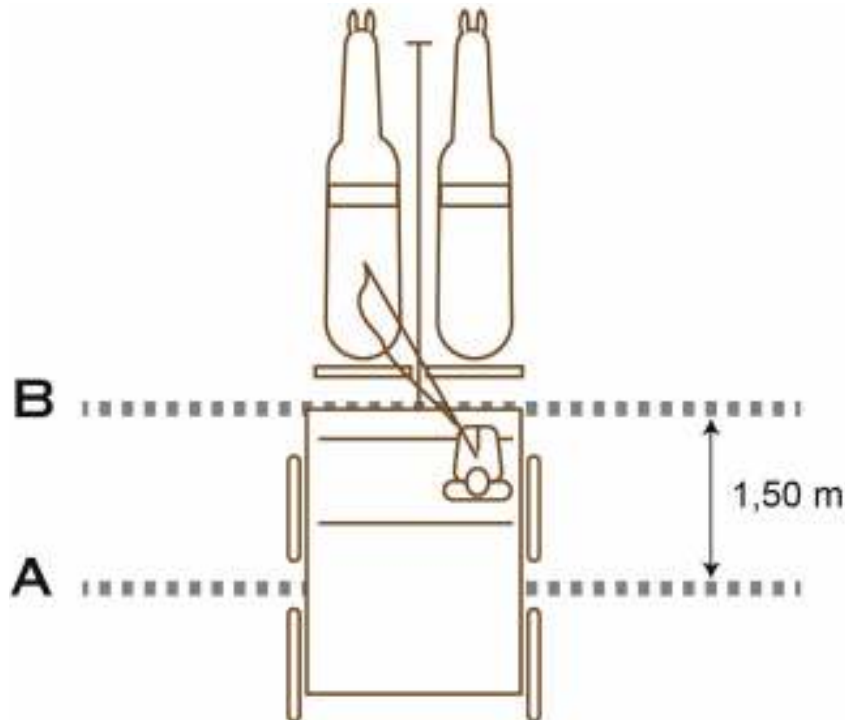

Score:

- Test completed without error
- Incorrect gait
- Front wheels / wheels not positioned between A & B
- The turnout did not remain standing for 20 seconds
- Coachman used the brakes
- Whip not held in the hand
- Coachman received assistance
- Failure to complete the skill test or not entering the obstacle correctly Maximum penalty points

Penalty Points

- 0
- 3
- 3
- 3
- 3
- 3
- 3
- 10

Obstacle Judge's name ..... Judge's signature: ..... Penalty Points: .....

## 2.4. Stopping/ Halt on a hill / on a descent

Carriage Number .....

Coachman's Name: .....

Gait: Walk

Walk up to Line A without stopping.. On an uphill or downhill gradient, the turnout must stand still for 10 seconds between lines A and B, unaided and without using the brakes. The front wheels of the carriage must not cross lines A and B.

The use of the brakes until the front wheels are in position is permitted / or, in the case of single-axle vehicles, the wheels are in front of line A.

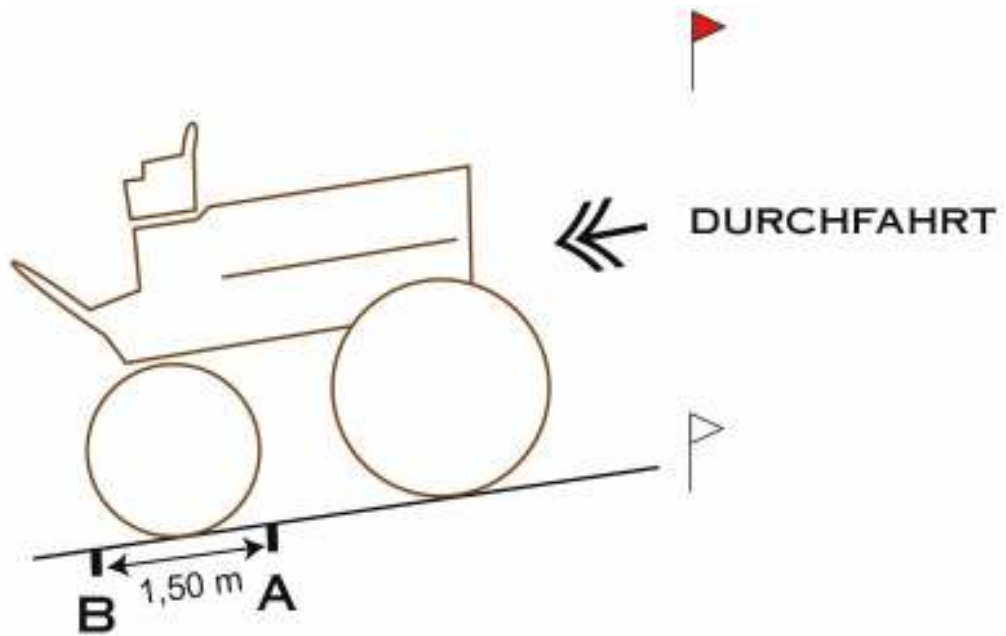

Score:

- Test completed without error
- Incorrect gait
- Stopping before line A
- Crossing line B before coming to a halt
- The turnout didn't stand still for 10 seconds
- The coachman used the brakes between A & B
- Whip not held in the hand
- Coachman received assistance
- Failure to complete the skill test or not entering the obstacle correctly Maximum penalty points

Penalty Points

- 0
- 3
- 3
- 3
- 3
- 3
- 3
- 3
- 10

Obstacle Judge's name ..... Judge's signature: ..... Penalty Points: .....

## 2. The Wooden Bridge

Carriage Number..... Coachman's Name : .....

Gait Trot, Stopping prohibited. Use of brakes through the whole obstacle is not permitted.  
 Drive the turnout over the wooden bridge from A to B without knocking the balls off the cones and without outside help.  
 The obstacle cones have a distance of 2.50 m between them for single and pairs, and 2.80 m for tandem, unicorns, teams and coaches

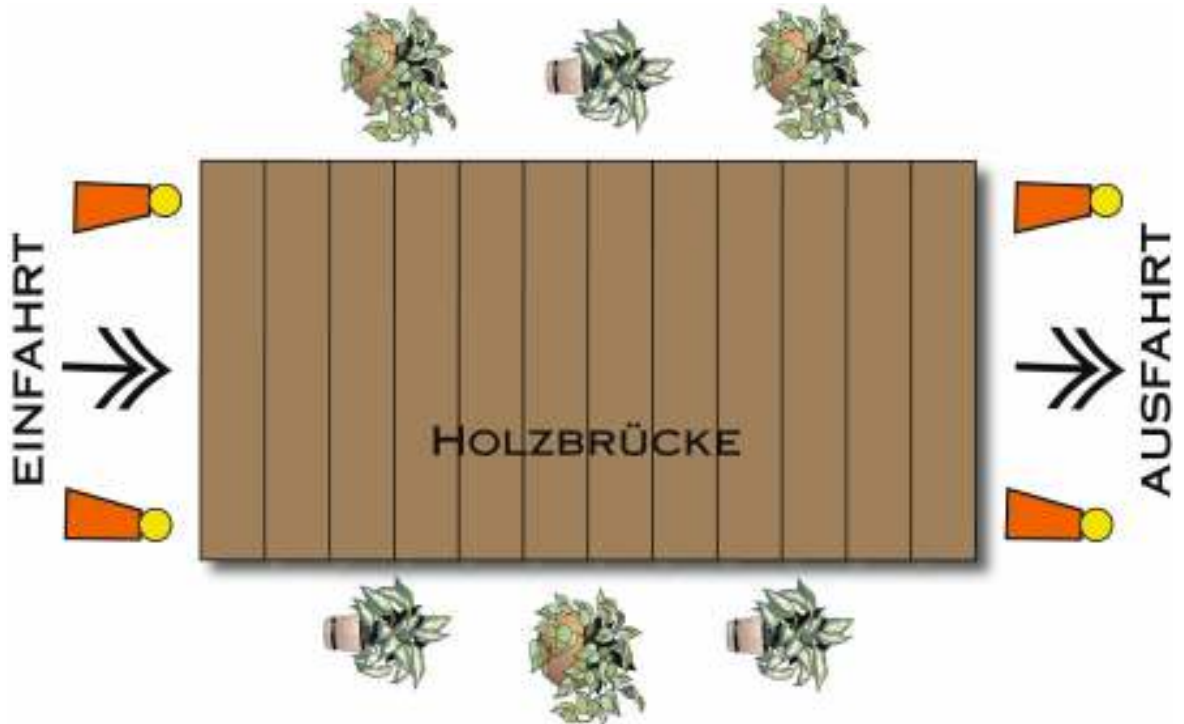

Score:

- |  | Penalty Points              |
|--|-----------------------------|
| • Test completed without error   | 0 <input type="checkbox"/>  |
| • Incorrect gait   | 3 <input type="checkbox"/>  |
| • The bridge was either not crossed, or not completely crossed                                     | 3 <input type="checkbox"/>  |
| • One or more balls were knocked down  | 3 <input type="checkbox"/>  |
| • The coachman used the brakes between   | 3 <input type="checkbox"/>  |
| • Whip not held in the hand  | 3 <input type="checkbox"/>  |
| • Coachman received assistance   | 3 <input type="checkbox"/>  |
| • Failure to complete the skill test or not entering the obstacle correctly Maximum penalty points | 10 <input type="checkbox"/> |

Obstacle Judge's name ..... Judge's signature: ..... Penalty Points: .....



## 4. Reinback (level or slight uphill surface)

Carriage Number..... Coachman's Name .....

Gait Walk

Turnout enters at a walk over lines B and A. Use of the brakes is not permitted throughout the obstacle. Stop the turnout with the rear wheels (wheels for 1-axle vehicles) behind line A without using the brakes. The turnout then stands still.

Then rein the carriage back until line B has been crossed with both rear wheels without knocking the balls off the cones, (both wheels for a two wheeler).

You may drive forward again to correct your direction as often as you wish, although the turnout may not be in the obstacle longer than three minutes. ( Time keeping by obstacle judge).

Leave the test in a forward direction over Line A.

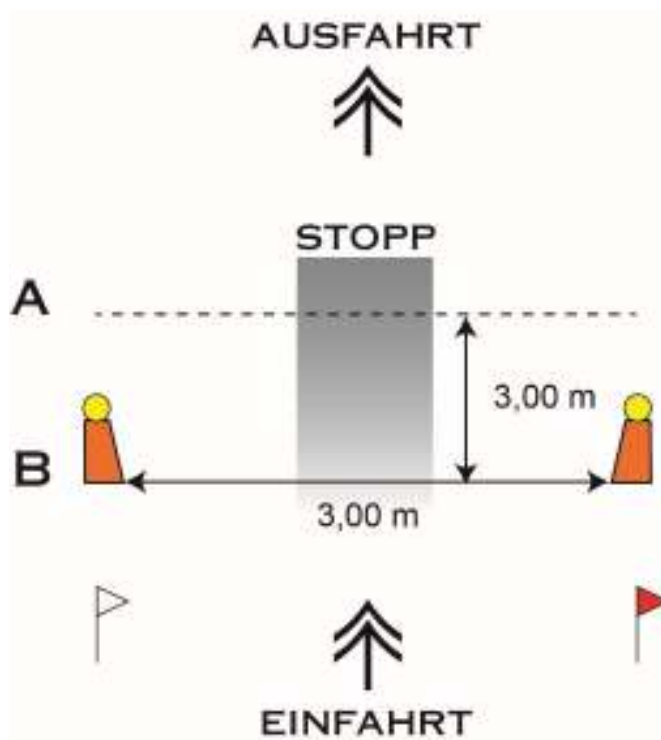

Score:

	Penalty Points
• Test completed without error	0 <input type="checkbox"/>
• Incorrect gait	3 <input type="checkbox"/>
• Line A was not crossed	3 <input type="checkbox"/>
• Line B was not reversed across	3 <input type="checkbox"/>
• One or more balls were knocked down	3 <input type="checkbox"/>
• The coachman used the brakes between	3 <input type="checkbox"/>
• Whip not held in the hand	3 <input type="checkbox"/>
• Coachman received assistance	3 <input type="checkbox"/>
• Failure to complete the skill test or not entering the obstacle correctly Maximum penalty points	10 <input type="checkbox"/>

Obstacle Judge's name ..... Judge's signature: ..... Penalty Points: .....

# 4. Champagne Glass

Carriage Number ..... Coachman's Name: .....

**Gait: Walk** Use of brakes throughout the whole obstacle is not permitted.

Approach the obstacle without outside help. As the coachman drives into the obstacle and before point A, the whip takes the reins and whip in his left hand and takes the glass from the tray (A) in his right hand, either in walk or from a standing position.

With the whip and reins still in the left hand, the coachman takes the glass, that he or a passenger has emptied, with his turnout at a walk without stopping to the tray (B). The coachman then stops without using the brakes and sets the glass down when the turnout comes to a standstill.

After putting down the glass the whip salutes and then exits the obstacle using the rein handling and gait of his choice.

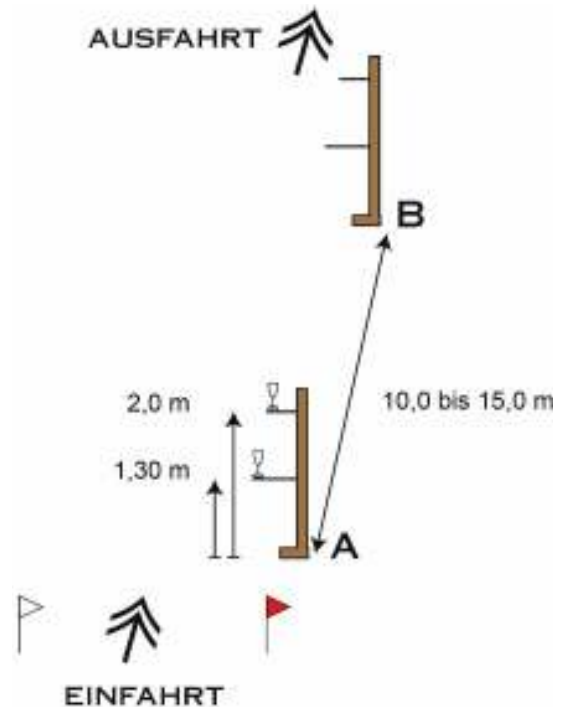

Score:

	Penalty Points
• Test completed without error	0 <input type="checkbox"/>
• Incorrect gait	3 <input type="checkbox"/>
• The glass was not picked up at A	3 <input type="checkbox"/>
• The glass was returned at Bt	3 <input type="checkbox"/>
• The turnout turnout did not stand still at B when the gals was returned	3 <input type="checkbox"/>
• Two handed rein handling or rein adjustment	3 <input type="checkbox"/>
• Coachman used the brakes	3 <input type="checkbox"/>
• Whip not held in the hand	3 <input type="checkbox"/>
• Coachman failed to salute	3 <input type="checkbox"/>
• Coachman received assistance	3 <input type="checkbox"/>
• Failure to complete the skill test or not entering the obstacle correctly Maximum penalty points	10 <input type="checkbox"/>

Name of test judge.....

judge's signature: .....

Penalty Points: .....

# 5. Passage / Drive through

## 5.1. Drive through with music

Carriage Number .....

Coachman's number: .....

Gait: Trot. Stopping / braking not permitted.

The turnout must drive unaided through a passage marked by two lines without crossing them.

The music can be on the left or right of the passage. The distance between the entrance and exit is between 15 and 20 meters. The music is turned on before the turnout arrives at the obstacle.

Gate width: 2,50 m Single, Pair and Tandem  
2,80 m 3- horses, teams & Coaches



Score	Penalty Points
Test completed without error	0 <input type="checkbox"/>
• Incorrect gait	3
• Crossing the border lines once, or more	3 <input type="checkbox"/>
• The coachman stopped or used the brakes	3 <input type="checkbox"/>
Whip not held in the hand	3 <input type="checkbox"/>
• Coachman received assistance	3 <input type="checkbox"/>
• Failure to complete the skill test or not entering the obstacle correctly	10 <input type="checkbox"/>
Maximum penalty points	

Name of test judge.....

judge's signature: .....

Penalty Points: .....

## 5.2. Passage / Drive through with tractor

Carriage Number ..... Coachman's name: .....

Gait: Trot. Stopping / braking not permitted.

The turnout must drive unaided through a passage marked by two lines without crossing them.

The tractor can be on the left or right of the passage. The distance between the entrance and exit is between 15 and 20 meters. The tractor can have its engine running when in position.

Gate width: 2,50 m Single, Pair and Tandem  
2,80 m 3- horses, teams & Coaches



Score	Penalty Points
Test completed without error	0 <input type="checkbox"/>
• Incorrect gait	3
• Crossing the border lines once, or more	3 <input type="checkbox"/>
• The coachman stopped or used the brakes	3 <input type="checkbox"/>
• Whip not held in the hand	3 <input type="checkbox"/>
• Coachman received assistance	3 <input type="checkbox"/>
• Failure to complete the skill test or not entering the obstacle correctly	Maximum penalty points 10 <input type="checkbox"/>

Name of test judge..... Judge's signature: ..... Penalty Points: .....

## 5.2. Passage / Drive through with Livestock

Carriage Number ..... Coachman's name: .....

Gait: Trot. Stopping / braking not permitted.

The turnout must drive unaided through a passage marked by two lines without crossing them.

The livestock can be on the left or right of the passage. The distance between the entrance and exit is between 15 and 20 meters.

Gate width: 2,50 m Single, Pair and Tandem  
2,80 m 3- horses, teams & Coaches

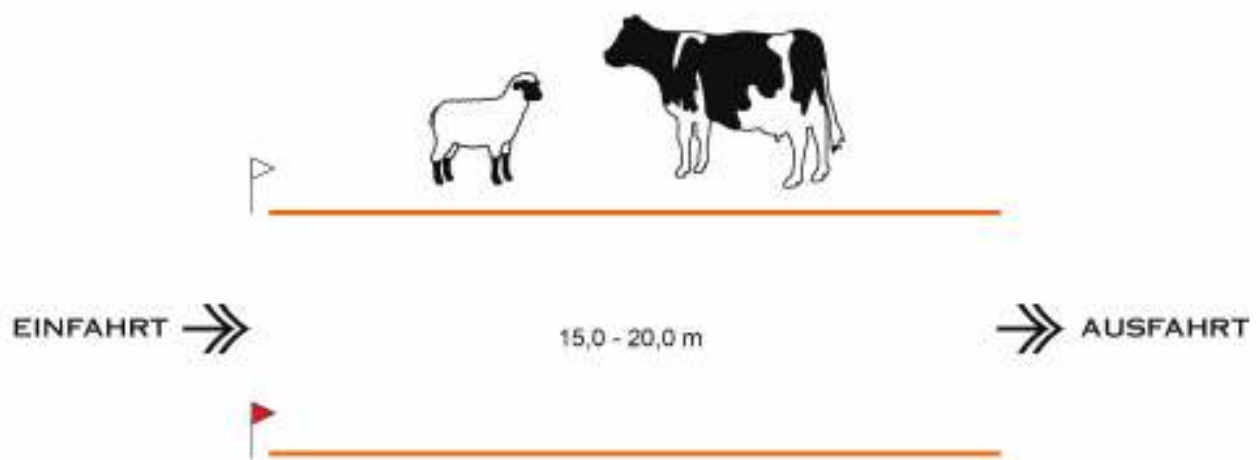

Score	Penalty Points
• Test completed without error	0 <input type="checkbox"/>
• Incorrect Gait	3 <input type="checkbox"/>
• Crossing the border lines once or more	3 <input type="checkbox"/>
• Coachman stopped or used the brakes	3 <input type="checkbox"/>
• Whip not held in the hand	3 <input type="checkbox"/>
• Coachman received help	3 <input type="checkbox"/>
• Did not undertake or complete the task, max. Points	10 <input type="checkbox"/>

Name of test judge..... Judge's signature: ..... Penalty Points: .....

### 5.4. Passage / Drive through with Salute

Carriage Number ..... Coachman's name: .....

Gait: Trot. Stopping / braking not permitted.

The coachman must have the reins in the left hand before entering the obstacle through Gate A. Drive through the passage without changing the position of the reins and salute with the right hand

The task is scored from the moment they traverse gate A.

The distance between the entrance and exit is between 15 and 20 meters.

Gate width: 2,50 m Single, Pair and Tandem  
 2,80 m 3- horses, teams & Coaches



Score	Penalty Points
• Test completed without error	0 <input type="checkbox"/>
• Incorrect Gait	3 <input type="checkbox"/>
• Crossing the border lines once or more	3 <input type="checkbox"/>
• Coachman stopped or used the brakes	3 <input type="checkbox"/>
• Whip not held in the hand	3 <input type="checkbox"/>
• Coachman received help	3 <input type="checkbox"/>
• Did not undertake or complete the task, max. Points	10 <input type="checkbox"/>

Name of test judge..... Judge's signature: ..... Penalty Points: .....

## 6. Driving between marked lines

### 6.1. Driving between marked lines / straight on

Carriage Number ..... Coachman's Name: .....

Gait Trot. Stopping or braking not permitted.

Without help the turnout must drive with the right front wheel between the two lines / without completely crossing the lines with the right front wheel, ( the right wheel in the case of single-axle vehicles). Scoring the task begins when the front wheel first drives between the parallel lines. The lines are 40 cm apart and about 15 meters long.



Score	Penalty Points
• Test completed without error	0 <input type="checkbox"/>
• Incorrect Gait	3 <input type="checkbox"/>
• Crossing the lines (touching the lines is not an error)	3 <input type="checkbox"/>
• Coachman stopped or used the brakes	3 <input type="checkbox"/>
• Whip not held in the hand	3 <input type="checkbox"/>
• Coachman received help	3 <input type="checkbox"/>
• Did not undertake or complete the task, max. Points	10 <input type="checkbox"/>

Name of test judge..... Judge's signature: ..... Penalty Points: .....

### 6.3. Driving between marked lines with a left bend

Carriage Number ..... Coachman's Name: .....

Gait Trot. Stopping or braking not permitted.

Without help the turnout must drive with the right front wheel between the two lines with a left bend without completely crossing the lines, ( the right wheel in the case of single-axle vehicles). Scoring the task begins when the front wheel first drives between the lines.

The lines are 40 cm apart and about 15 meters long, with a minimum 15m radius.

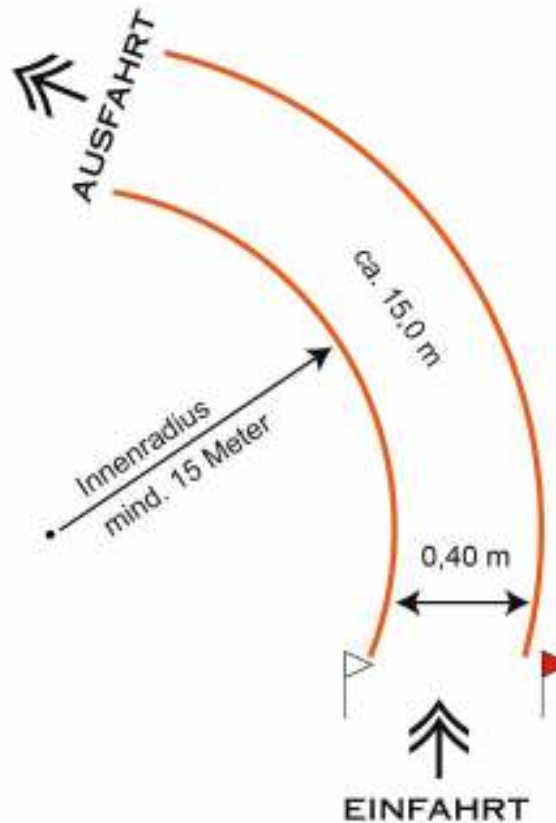

Score	Penalty Points
• Test completed without error	0 <input type="checkbox"/>
• Incorrect Gait	3 <input type="checkbox"/>
• Crossing the lines (touching the lines is not an error)	3 <input type="checkbox"/>
• Coachman stopped or used the brakes	3 <input type="checkbox"/>
• Whip not held in the hand	3 <input type="checkbox"/>
• Coachman received help	3 <input type="checkbox"/>
• Did not undertake or complete the task, max. Points	10 <input type="checkbox"/>

Name of test judge..... Judge's signature: ..... Penalty Points: .....



#### 6.4. Driving between marked lines with a right bend

Carriage Number ..... Coachman's Name: .....

Gait Trot. Stopping or braking not permitted.

Without help the turnout must drive with the right front wheel between the two lines with a right bend without completely crossing the lines, ( the right wheel in the case of single-axle vehicles).

Scoring the task begins when the front wheel first drives between the lines.

The lines are 40 cm apart and about 15 meters long, with a minimum 15m radius.

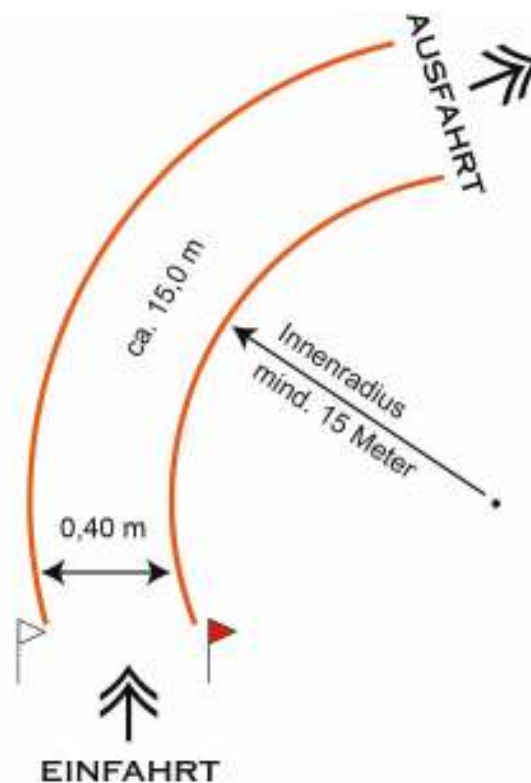

Score	Penalty Points
• Test completed without error	0 <input type="checkbox"/>
• Incorrect Gait	3 <input type="checkbox"/>
• Crossing the lines (touching the lines is not an error)	3 <input type="checkbox"/>
• Coachman stopped or used the brakes	3 <input type="checkbox"/>
• Whip not held in the hand	3 <input type="checkbox"/>
• Coachman received help	3 <input type="checkbox"/>
• Did not undertake or complete the task, max points	10 <input type="checkbox"/>

Name of test judge..... Judge's signature: ..... Penalty Points: .....

### 6.6. Driving between marked lines next to a livestock pen

Carriage Number ..... Coachman's Name: .....

Gait Trot. Stopping or braking not permitted.

Traverse the cones at A and drive on past the nearby livestock pen close so that the right wheels remain to the right of the line.

The evaluation of the task begins when the horses reach the pair of cones.

For singles and pairs the cones have a width of 2.5m, for unicorn, teams and coaches 2.8m

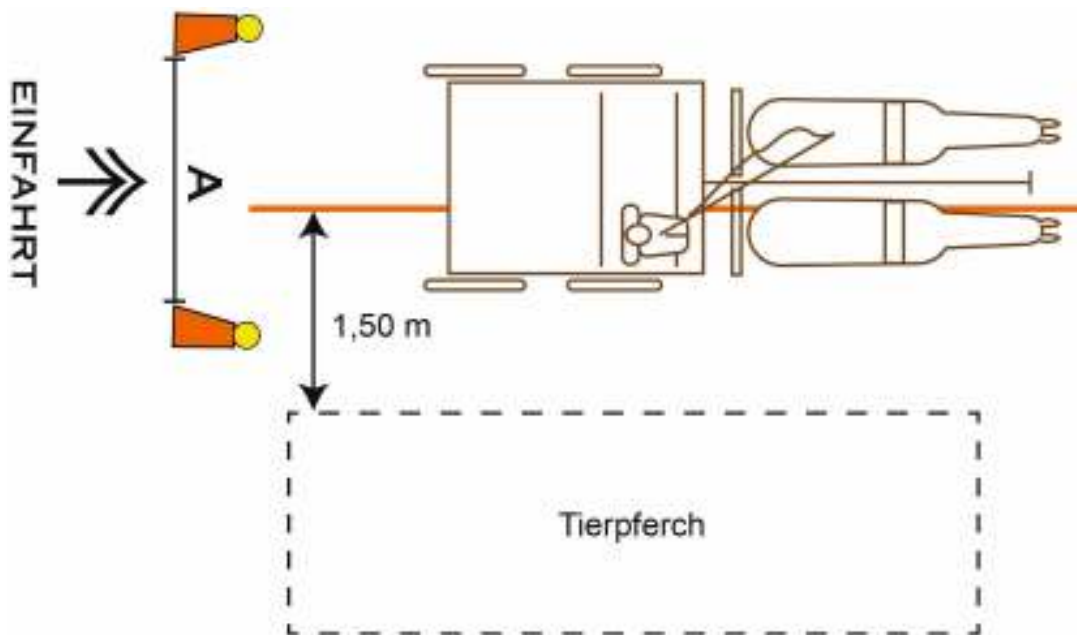

Score	Penalty Points
• Test completed without error	0 <input type="checkbox"/>
• Incorrect Gait	3 <input type="checkbox"/>
• The boundary lines were crossed one or more times, distance greater than 1.5m	3 <input type="checkbox"/>
• Coachman stopped or used the brakes	3 <input type="checkbox"/>
• Whip not held in the hand	3 <input type="checkbox"/>
• Coachman received help	3 <input type="checkbox"/>
• Did not undertake or complete the task, max points	10 <input type="checkbox"/>

Name of test judge..... Judge's signature: ..... Penalty Points: .....

# 7. Driving Circles

## 7.1. Circle Left

Carriage Number ..... Coachman's Name: .....

Gait Trot. Stopping or braking not permitted.

Drive a left handed circle ,unaided, with a minimum 2m diameter, without touching the cones and/or knocking down balls,; starting and finishing through the same gate / pair of cones.

The reins must be in the left hand when the coachman arrives at the cones, and the circle then driven using this rein handling position. Once the turnout goes through the cones **for the second time**, the coachman may then adopt his own rein handling method.

The whip may be used with the free hand when needed.

For singles and pairs the cones have a width of 2.5m, for unicorn, teams and coaches 2.8m

The Test commences when driving through the start flags at A and concludes **once the entire turnout has traversed the cones fully for a second time**.

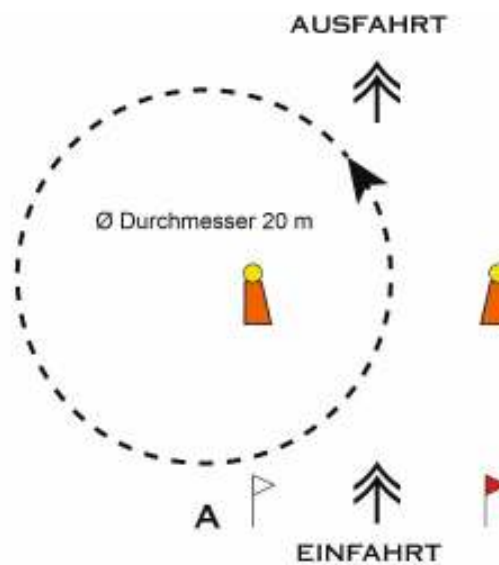

Score	Penalty Points
• Test completed without error	0 <input type="checkbox"/>
• Incorrect Gait	3 <input type="checkbox"/>
• One or more balls knocked down	3 <input type="checkbox"/>
• The cones were not driven through twice as part of the circle	3 <input type="checkbox"/>
• Two handed rein handling or adjustment	
• Coachman stopped or used the brakes	3 <input type="checkbox"/>
• Coachman received help	3 <input type="checkbox"/>
• Did not undertake or complete the task, max points	10 <input type="checkbox"/>

Name of test judge..... Judge's signature: ..... Penalty Points: .....

## 7.2. Circle right

Carriage Number ..... Coachman's Name: .....

Gait Trot. Stopping or braking not permitted.

Drive a right handed circle ,unaided, with a minimum 2m diameter, without touching the cones and/or knocking down balls,; starting and finishing through the same gate / pair of cones.

The reins must be in the left hand when the coachman arrives at the cones, and the circle then driven using this rein handling position. Once the turnout goes through the cones **for the second time**, the coachman may then adopt his own rein handling method.

The whip may be used with the free hand when needed.

For singles and pairs the cones have a width of 2.5m, for unicorn, teams and coaches 2.8m

The Test commences when driving through the start flags at A and concludes **once the entire turnout has traversed the cones fully for a second time.**

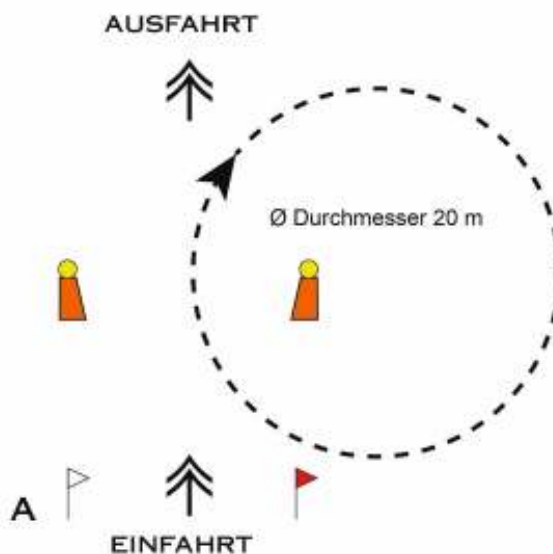

Score	Penalty Points
• Test completed without error	0 <input type="checkbox"/>
• Incorrect Gait	3 <input type="checkbox"/>
• One or more balls knocked down	3 <input type="checkbox"/>
• The cones were not driven through twice as part of the circle	3 <input type="checkbox"/>
• Two handed rein handling or adjustment	
• Coachman stopped or used the brakes	3 <input type="checkbox"/>
• Coachman received help	3 <input type="checkbox"/>
• Did not undertake or complete the task, max points.	10 <input type="checkbox"/>

Name of test judge..... Judge's signature: ..... Penalty Points: .....

### 7.3. Half Circle right through two pairs of cones

Carriage Number ..... Coachman's Name: .....

Gait Trot. Stopping or braking not permitted.

Passing through the pair of cones on the left (A) and execute a right half circle with a diameter of 20 m without outside help. The passage is delineated by two pairs of cones (topped with balls).

One handed rein handling in the left hand must be adopted no later than arriving at A. After passing through the pair of cones B (coachman level with cones), rein handling of choice. The whip may be used with the freehand.

Scoring commences upon driving through the cones at A, and ends when the complete turnout has driven traversed the right hand pair of cones at B.

For singles and pairs the cones have a width of 2.5m, for unicorn, teams and coaches 2.8m.

Each pair of cones must be driven through once.

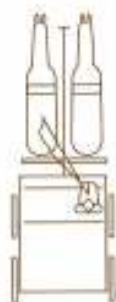
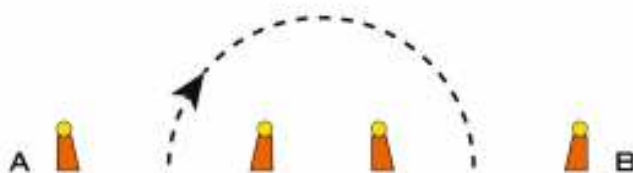

Score	Penalty Points
• Test completed without error	0 <input type="checkbox"/>
• Incorrect Gait	3 <input type="checkbox"/>
• The cones were not driven through twice as part of the semi circle	3 <input type="checkbox"/>
• Two handed rein handling or adjustment	3 <input type="checkbox"/>
• Coachman stopped or used the brakes	
• One or more balls were knocked down	3 <input type="checkbox"/>
• Coachman received help	3 <input type="checkbox"/>
• Did not undertake or complete the task.	10 <input type="checkbox"/>

Name of test judge..... Judge's signature: ..... Penalty Points: .....

### 7.4. Half Circle left through two pairs of cones

Carriage Number ..... Coachman's Name: .....

Gait Trot. Stopping or braking not permitted.

Passing through the pair of cones on the right(A) and execute a left half circle with a diameter of 20 m without outside help. The passage is delineated by two pairs of cones (topped with balls).

One handed rein handling in the left hand must be adopted no later than arriving at A. After passing through the pair of cones B (coachman level with cones), rein handling of choice. The whip may be used with the freehand.

Scoring commences upon driving through the cones at A, and ends when the complete turnout has driven traversed the right hand pair of cones at B.

For singles and pairs the cones have a width of 2.5m, for unicorn, teams and coaches 2.8m.

Each pair of cones must be driven through once.

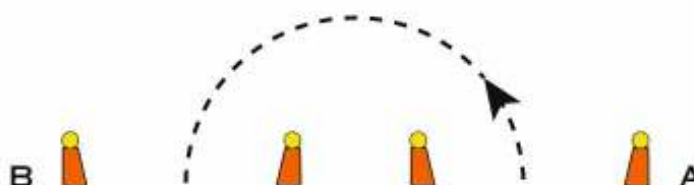

Score	Penalty Points
• Test completed without error	0 <input type="checkbox"/>
• Incorrect Gait	3 <input type="checkbox"/>
• The cones were not driven through twice as part of the semi circle	3 <input type="checkbox"/>
• Two handed rein handling or adjustment	3 <input type="checkbox"/>
• Coachman stopped or used the brakes	
• One or more balls were knocked down	3 <input type="checkbox"/>
• Coachman received help	3 <input type="checkbox"/>
• Did not undertake or complete the task.	10 <input type="checkbox"/>

Name of test judge..... Judge's signature: ..... Penalty Points: .....

# 8. Use of the Whip

## 8.1. Knocking balls off with the whip

Carriage number ..... Coachman's Name: .....

Gait Walk or Trot. Stopping or braking not permitted.

Before driving into the obstacle at A ensure the reins are in the left hand. You then drive on with the reins in the left hand and the whip in the right. The test begins when you cross the line at A.

Traverse line A and knock the balls off the cones with the whip as you drive forward, (the balls are not filled with water). Exit at B at which point rein handling may be of the coachman's choice.

Number of cones with balls, 3 - 5.

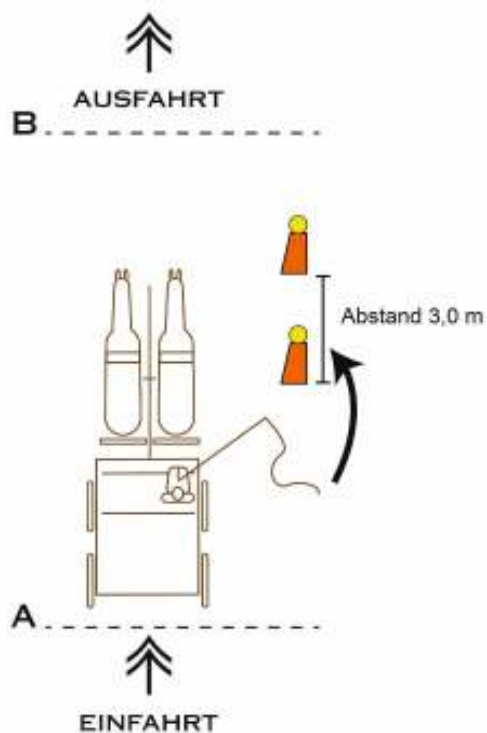

Score	Penalty Points
• Test completed without error	0 <input type="checkbox"/>
• Incorrect Gait	3 <input type="checkbox"/>
• Not all the balls were knocked down with the whip	3 <input type="checkbox"/>
• Two handed rein handling or adjustment	3 <input type="checkbox"/>
• Coachman stopped or used the brakes	3 <input type="checkbox"/>
• Coachman received help	3 <input type="checkbox"/>
• Did not undertake or complete the task, max. Points.	10 <input type="checkbox"/>

Name of test judge..... Judge's signature: ..... Penalty Points: .....

## 8.2. Ring a Bell with the whip

Carriage number: ..... Coachman's Name: .....

Gait Walk or Trot. Stopping or braking not permitted.

Before driving into the obstacle at A ensure the reins are in the left hand. You then drive on with the reins in the left hand and the whip in the right. The test begins when you cross the line at A.

Traverse the line at A and then ring the bell with the whip so it can be clearly heard.

Exit at B, from which point rein handling of the coachman's choice

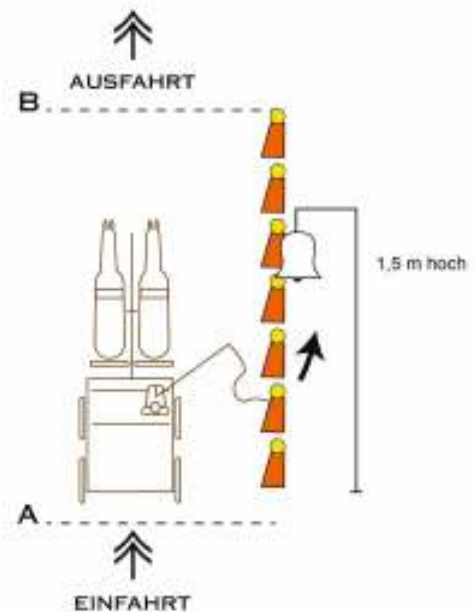

Score	Penalty Points
• Test completed without error	0 <input type="checkbox"/>
• Incorrect Gait	3 <input type="checkbox"/>
• The bell was not rung with the whip	3 <input type="checkbox"/>
• Two handed rein handling or adjustment	3 <input type="checkbox"/>
• Coachman stopped or used the brakes	3 <input type="checkbox"/>
• Coachman received help	3 <input type="checkbox"/>
• Did not undertake or complete the task, max. Points.	10 <input type="checkbox"/>



**8.3. Folding a Whip**  
*only for Tandem, Unicorn, Teams and Coaches*

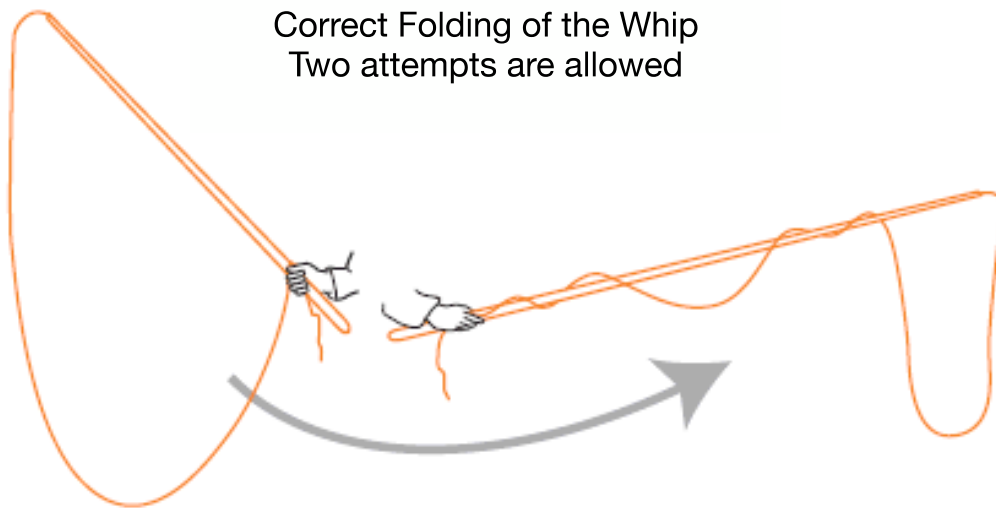

Carriage Number..... Coachman's Name: .....

Score:

Penalty Points

- Whip correctly folded 0
- Whip incorrectly folded 3
- Not attempting to fold the whip, max Points 6

Name of test judge..... Judge's signature: ..... Penalty Points: .....

## 9. The Turnout in Motion

Carriage Number ..... Coachman's Name: .....

Arrive at a trot or walk, and without using the brakes, stop at the marked spot, salute and stand for 10 seconds without a groom dismounting.

Then let the team trot on.

Drive a distance of 300m in working trot. There is a right-hand bend on this stretch that should be driven correctly.

The evaluation criteria in the movement are:-

- rhythm, suppleness, momentum, contact, standing correctly on the aids
- Driving ability and effect of the aids, rein handling,
- Correct driving of a right turn (giving aids and rein handling), position and the horses ability to bend
- 

Assessment without score sheet

(Verbal evaluation - how should this be integrated into the penalty points?)

**OR**

Score	Penalty Points
• Test completed without error	0 <input type="checkbox"/>
• Incorrect Gait	3 <input type="checkbox"/>
• The turnout did not stand for 10 seconds	3 <input type="checkbox"/>
• Right turn incorrectly driven	3 <input type="checkbox"/>
• Coachman stopped or used the brakes	3 <input type="checkbox"/>
• Coachman received help	3 <input type="checkbox"/>
• Did not undertake or complete the task, max. Points.	10 <input type="checkbox"/>

Name of test judge..... Judge's signature: ..... Penalty Points: .....